

ATTENTION

NO ONE SHOULD BE ALLOWED ON ANY G2T TRUSS UNTIL ALL HANGERS & CROSS BRIDGING, IF REQ'D, AND TEMPORARY BRACING ARE IN PLACE AND NAILED SECURELY. SERIOUS ACCIDENTS MAY OCCUR UNLESS CARE IS TAKEN TO PROPERLY BRACE DURING CONSTRUCTION. THIS DETAIL SHOULD BE USED AS A GUIDELINE FOR BRACING.

STACK BUILDING MATERIALS OVER WALLS, GIRDERS OR BEAMS ONLY

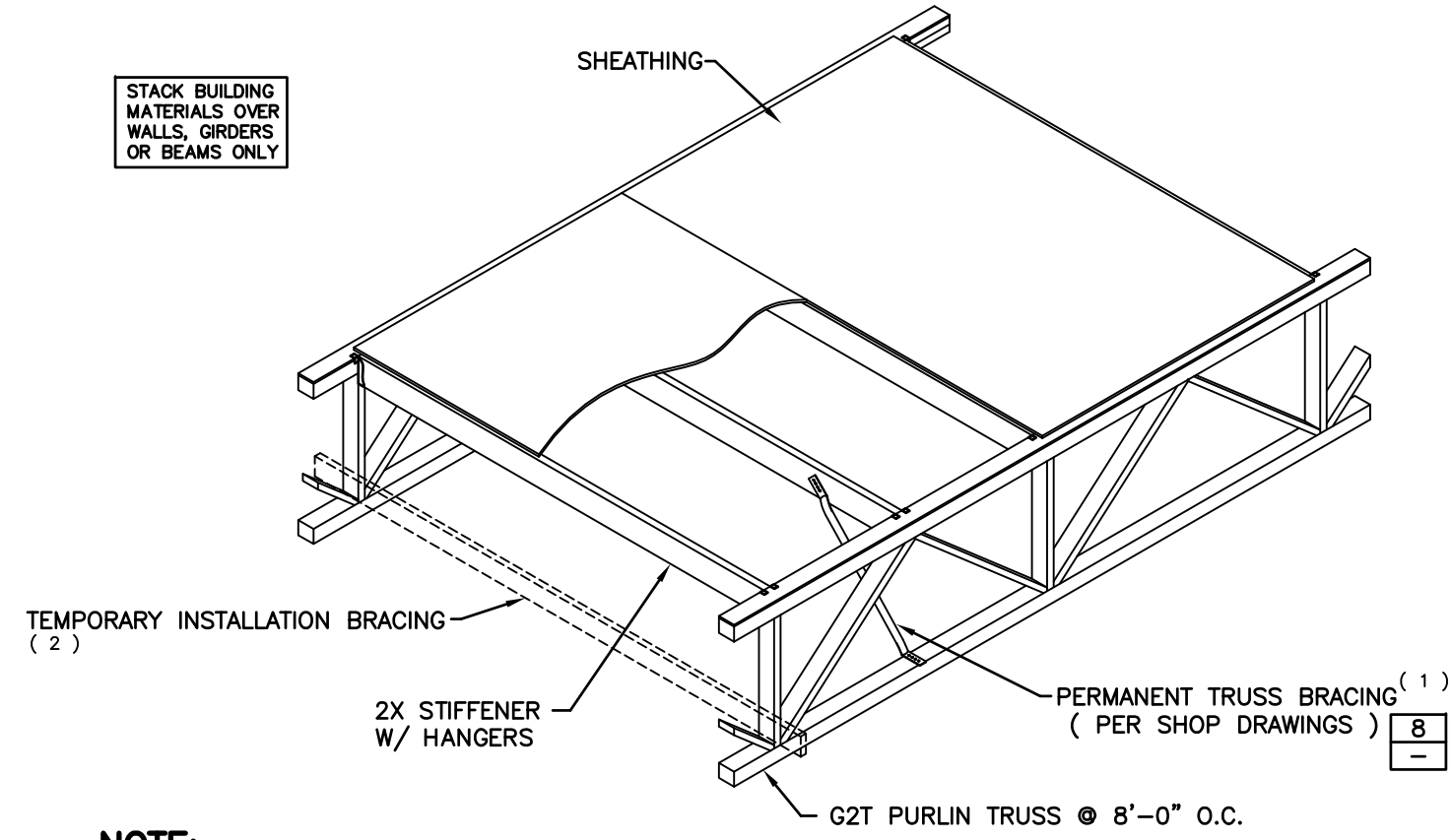

NOTE:

- PERMANENT BRACING SHALL BE PER FABRICATOR'S RECOMMENDATIONS. IF PERMANENT BRACING IS USED AS THE INSTALLATION BRACING, IT MUST BE INSTALLED AS EACH TRUSS IS PLACED. A MINIMUM OF TWO (2) INSTALLATION BRACES ARE REQUIRED AT ALL SPANS GREATER THAN 32'-0".
- INSTALLATION BRACING IN ADDITION TO OR IN LEIU OF PERMANENT TRUSS BRACING TO BE DESIGNED AND INSTALLED BY THE INSTALLATION CONTRACTOR.

1 ERECTION BRACING

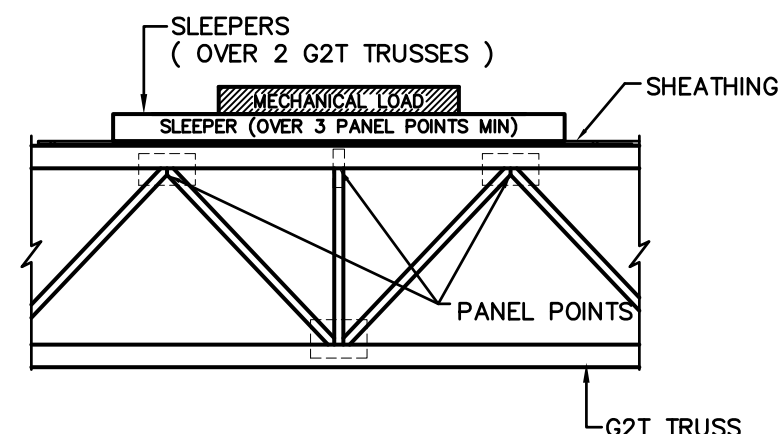

PARALLEL CONDITION

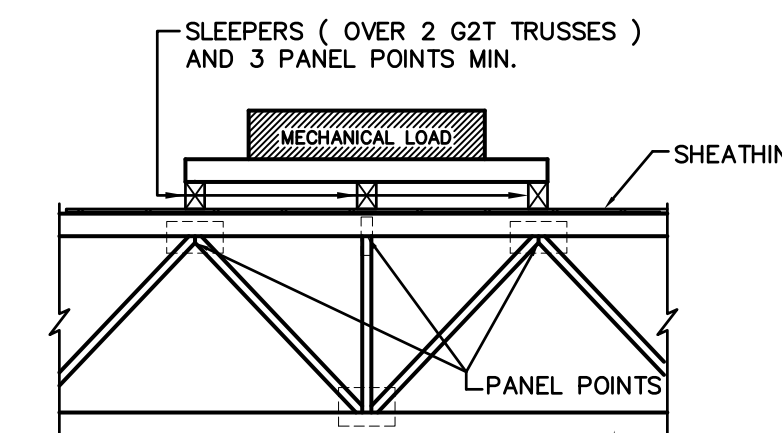

PERPENDICULAR CONDITION

NOTES

- COORDINATE MECHANICAL LOCATIONS WITH LAYOUT AND G2T CALCULATIONS
- SLEEPERS MUST BE LOCATED AT PANEL POINTS

2 MECHANICAL LOADS ON G2T TRUSSES

G2T TRUSS NAILING CHART (MINIMUM ON CENTER SPACING)

NAIL TYPE	NAIL SIZE	MSR (M)		LSL (L)		LVL (V)			
		FACE	EDGE	FACE	EDGE	FACE	EDGE		
8d	BOX	0.113"x2 1/2"	2"	2"	3"	3"	1"	2"	1"
	COMMON	0.131"x2 1/2"	2"	2"	3"	3"	1"	3"	1"
10d	BOX	0.128"x3"	2"	2"	3"	3"	1"	3"	1"
	COMMON	0.148"x3"	3"	4"	3"	4"	1"	4"	1"
12d	BOX	0.128"x3 1/4"	3"	2"	3"	3"	1"	3"	1"
	COMMON	0.148"x3 1/4"	3"	4"	3"	4"	1"	4"	1"
16d	BOX	0.135"x3 1/2"	3"	3"	3"	4"	2"	3"	2"
	SINKER	0.148"x3 1/4"	3"	4"	3"	4"	2"	4"	2"
COMMON	0.162"x3 1/2"	4"	6"	3"	6"	2"	6"	2"	

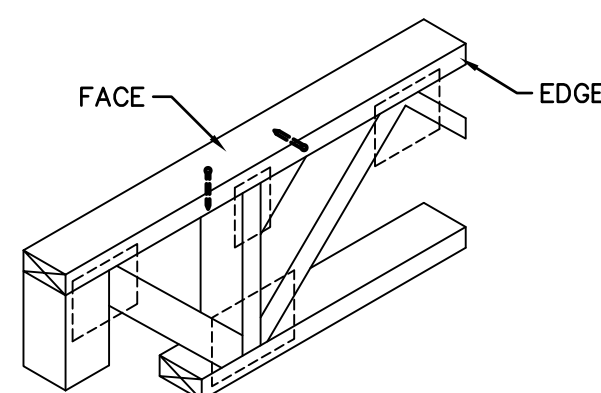

G2T TRUSS

3 NAILING CHART

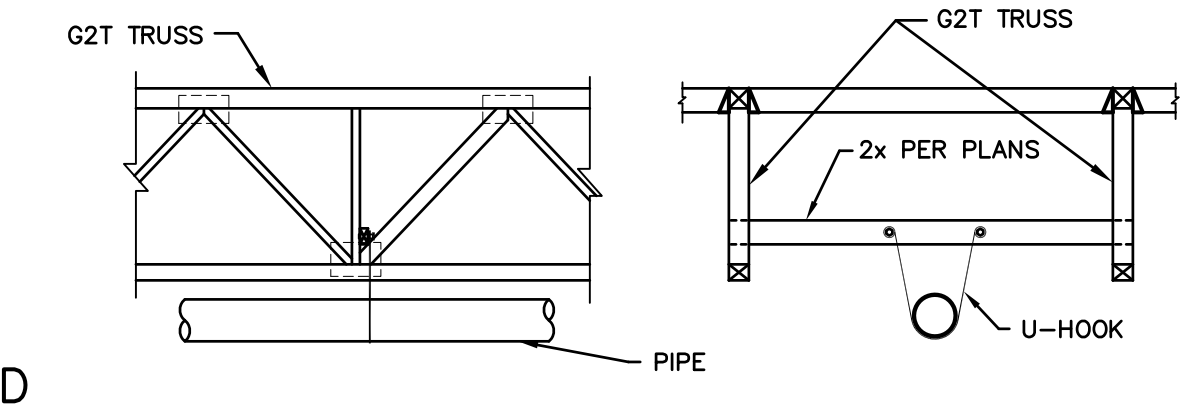
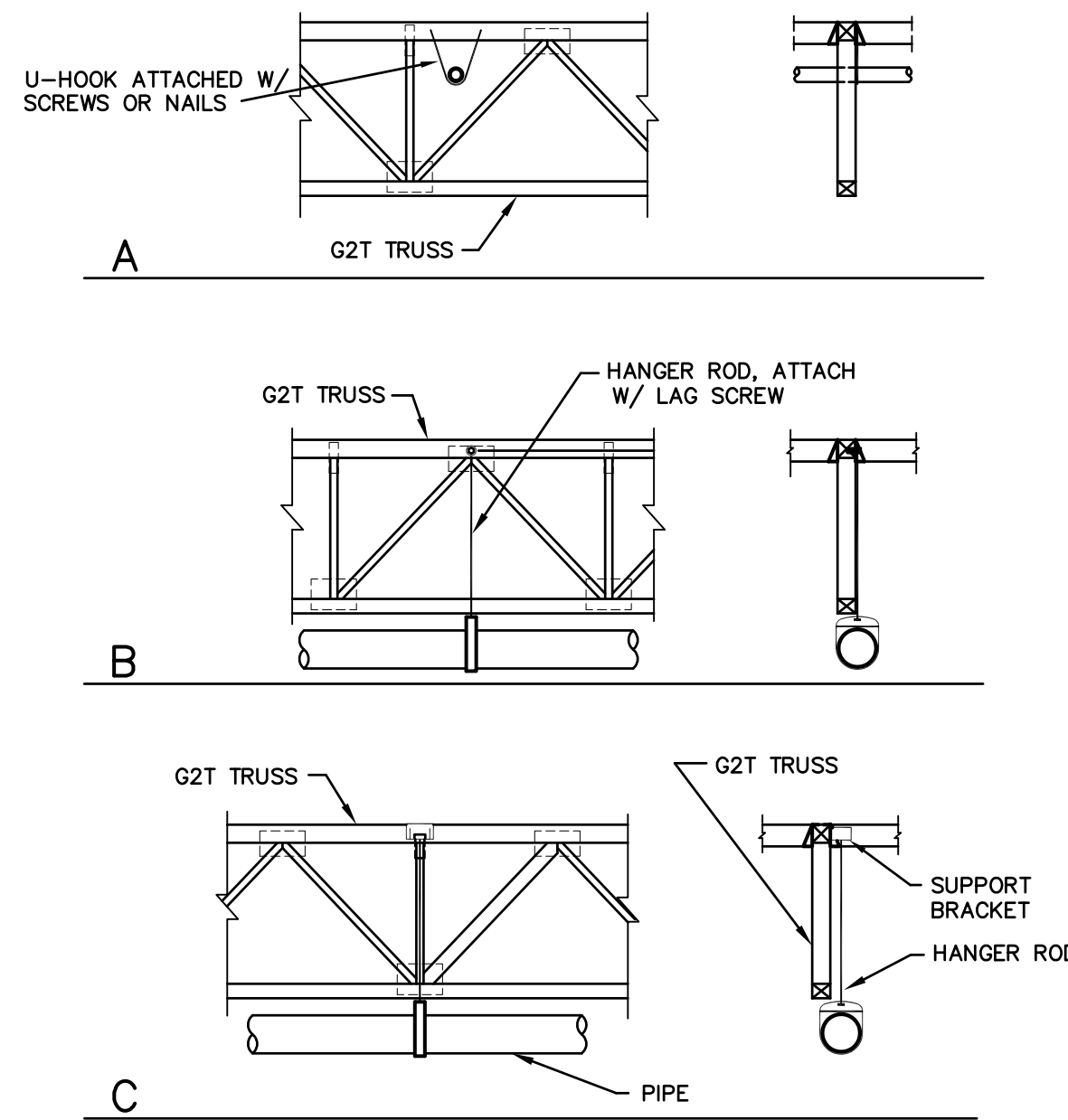

NOTES:

- WOOD SCREWS WITH A MAXIMUM DIAMETER OF 5/16" MAY BE USED ANYWHERE ON THE TOP CHORD OF THE G2T TRUSS WITHOUT PRE-DRILLING A PILOT HOLE, UNLESS NOTED OTHERWISE ON PLANS.
- BOLTS OR LAG SCREWS HAVING A DIAMETER OF 3/8" OR GREATER MUST BE LOCATED IN THE CONNECTOR PLATE AT THE TOP CHORD OF THE G2T TRUSS.
- BOLTS OR LAG SCREWS HAVING A DIAMETER OF 1/2" OR GREATER MUST HAVE PRE-DRILLED HOLES LOCATED IN THE CONNECTOR PLATE AT THE TOP CHORD OF THE G2T TRUSS.
- DO NOT DRILL HOLES, DRIVE HEAVY SCREWS, OR USE LAG BOLTS IN THE BOTTOM CHORD OF G2T TRUSS.
- COORDINATE ATTACHMENT OF SPRINKLER PIPE 4" DIAMETER AND LARGER WITH TRUSS LAYOUT AND CALCULATIONS.
- BOLTS OR LAG SCREWS INTO THE TOP CHORD SHALL BE LIMITED TO A MAXIMUM DIAMETER AS FOLLOWS: 1/2" @ G2T44; 7/8" @ G2T46
- NOTE: ALL CONNECTIONS, CLAMPS, HANGERS, RODS, OR SUPPORT ETC.... SHALL BE IN ACCORDANCE WITH NFPA 13

4 FIRE SPRINKLER ATTACHMENT DETAIL

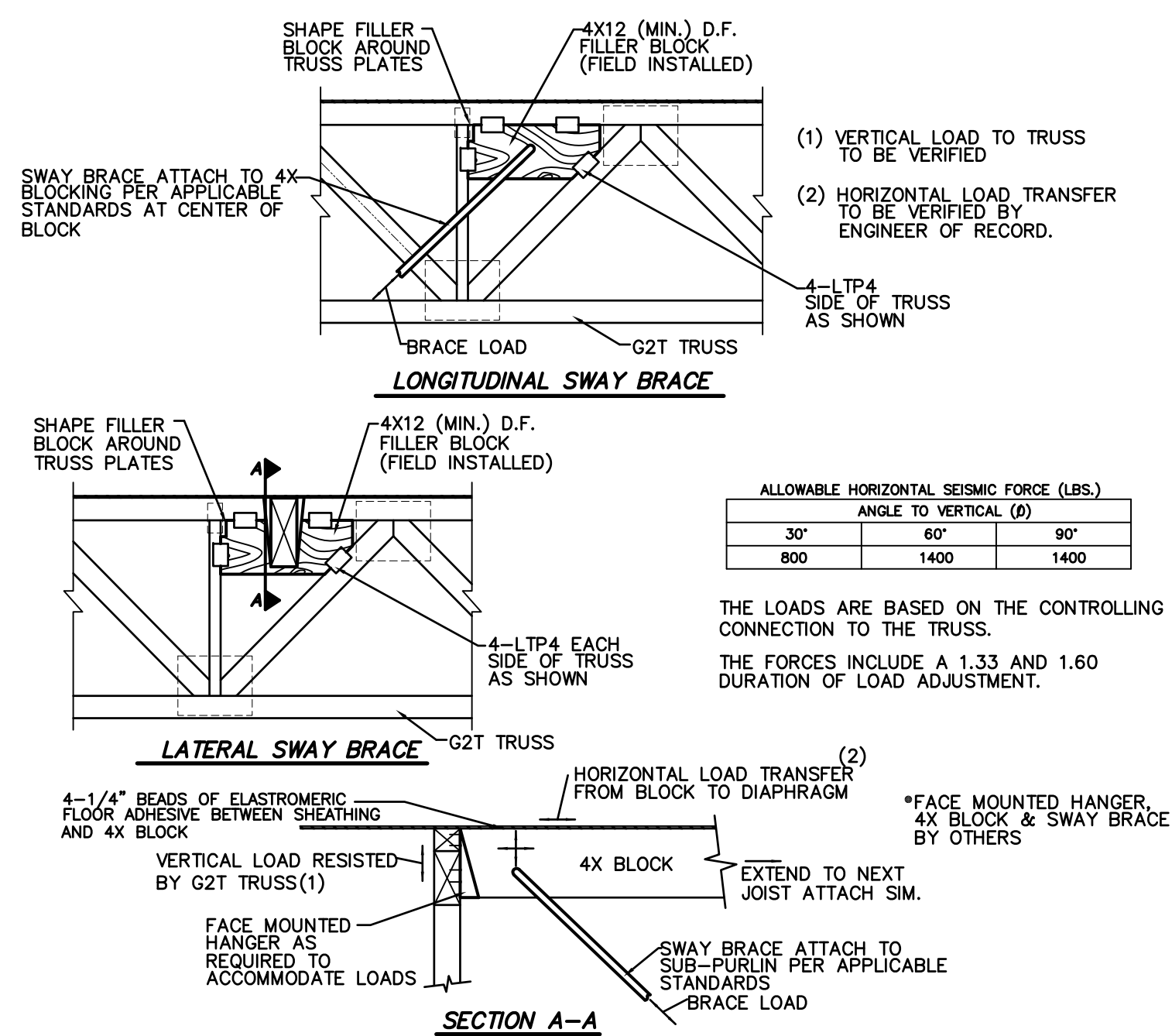

ALLOWABLE HORIZONTAL SEISMIC FORCE (LBS.)	ANGLE TO VERTICAL (°)
300	60°
800	90°
1400	1400

THE LOADS ARE BASED ON THE CONTROLLING CONNECTION TO THE TRUSS. THE FORCES INCLUDE A 1.33 AND 1.60 DURATION OF LOAD ADJUSTMENT.

5A FIRE SPRINKLER SWAY BRACE DETAIL

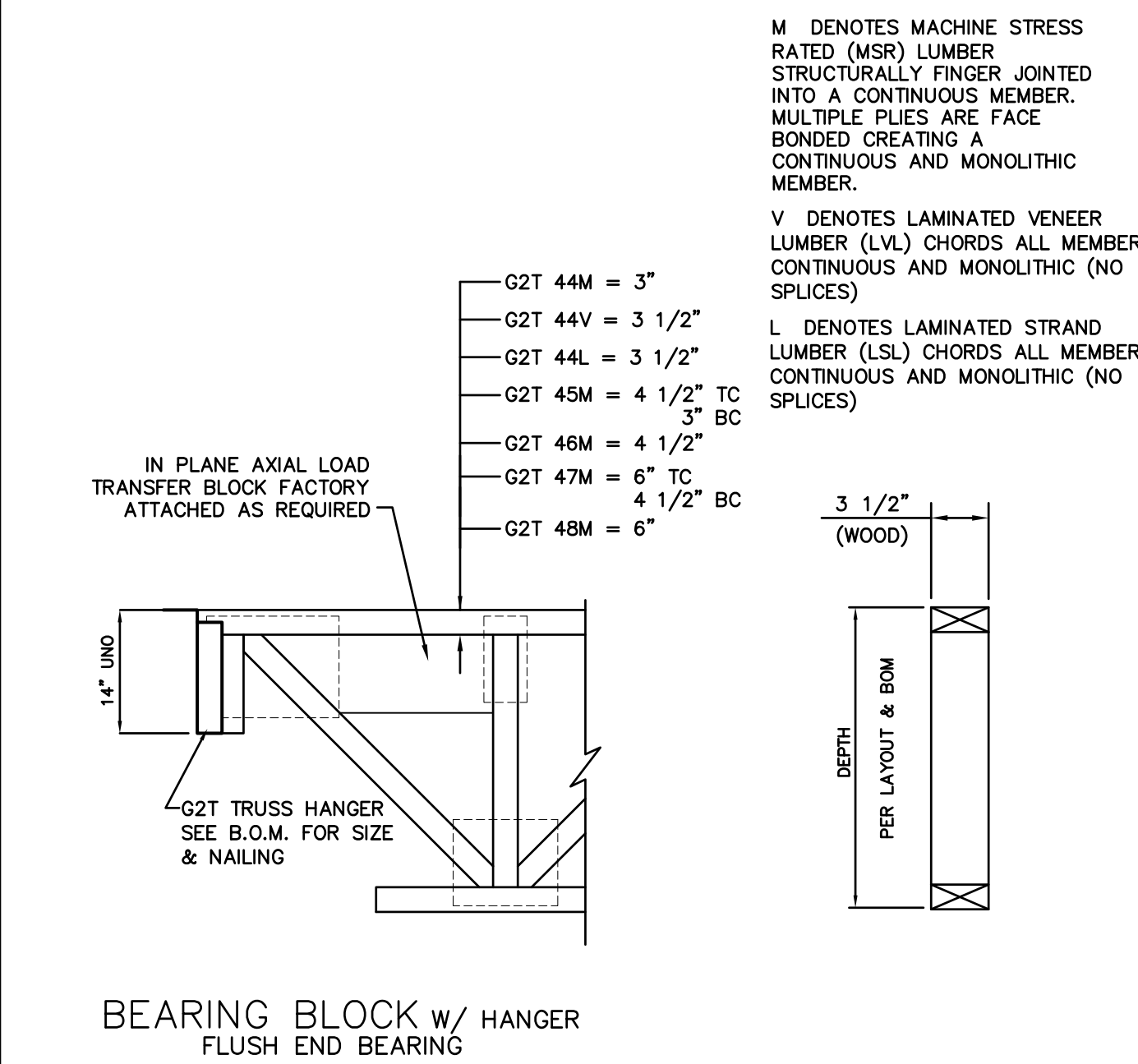

6 G2T TRUSS GENERAL DIMENSIONS

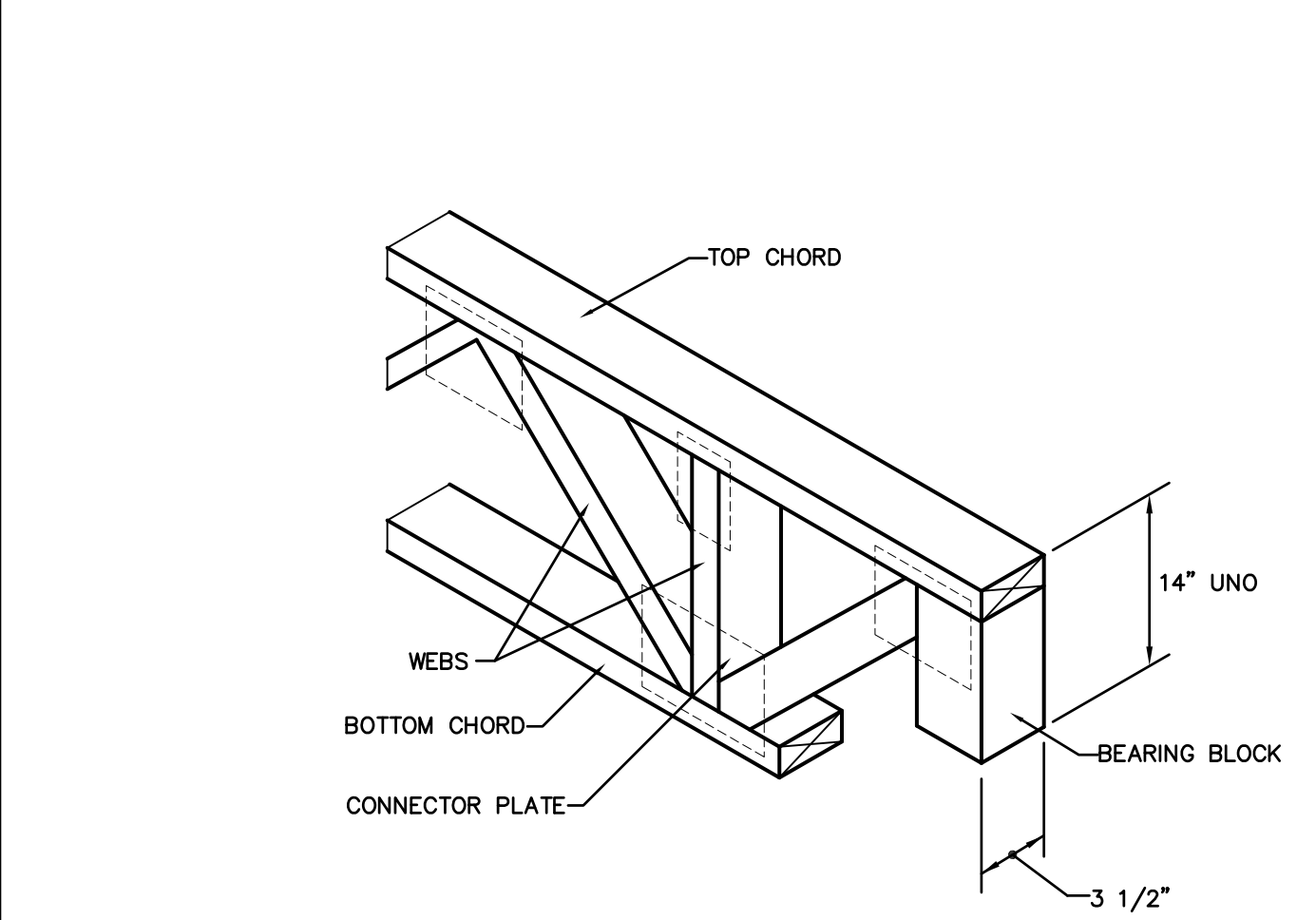

7 G2T TRUSS W/ BEARING BLOCK

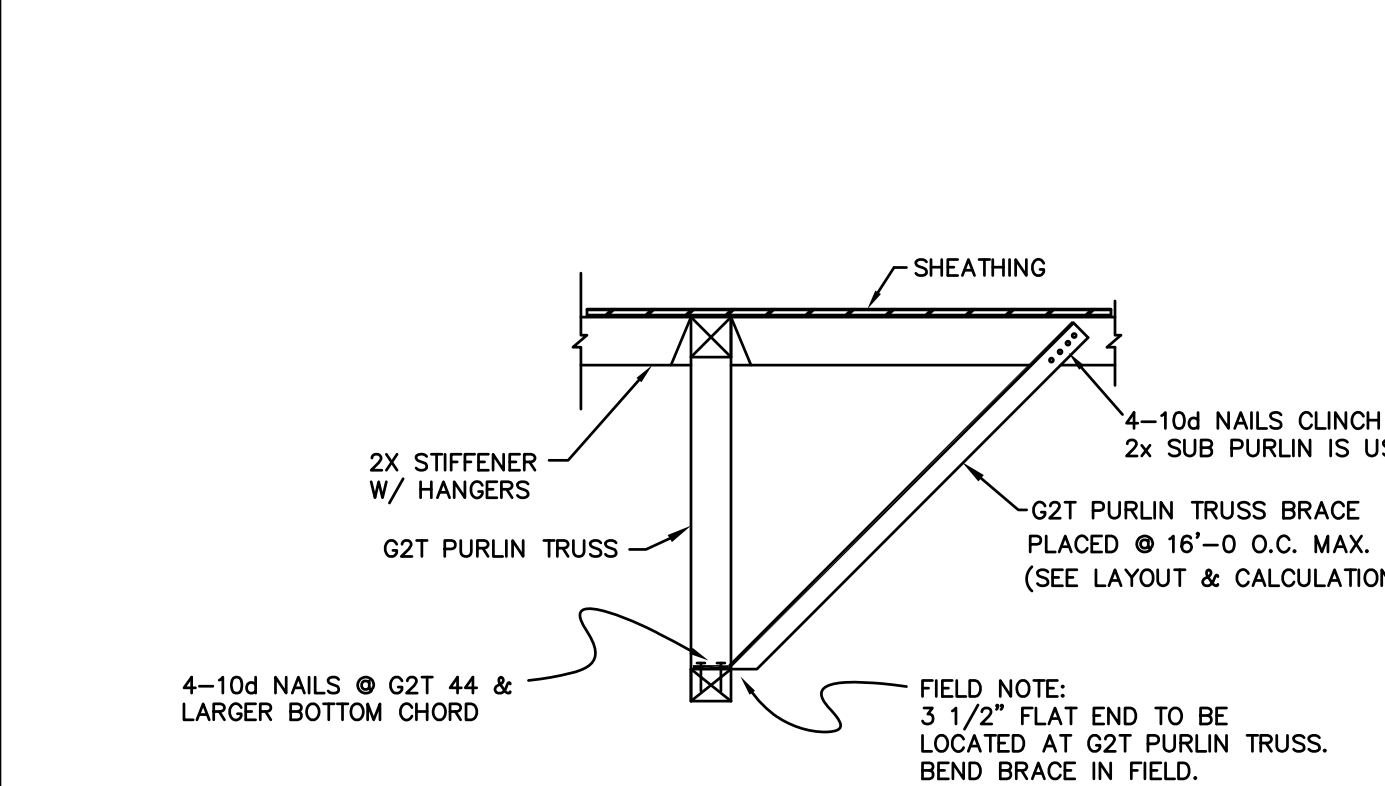

8 PERMANENT G2T ERECTION BRACE

G2T PURLIN JOIST PRODUCT COVER SHEET

JOB SITE HANDLING OF G2T OPEN WEB TRUSSES

IT IS THE BUILDING CONTRACTOR'S RESPONSIBILITY TO UNLOAD THE G2T TRUSSES FROM THE TRUCK AND FOR ALL HANDLING THEREAFTER. THE G2T OPEN WEB TRUSSES GUARANTEE ONLY APPLIES AS LONG AS THE PRODUCT IS NOT DAMAGED OR ALTERED IN ANY WAY, IS INSTALLED IN A WORKMANLIKE MANNER. G2T TRUSSES WILL BE DELIVERED TO THE JOBSITE IN BUNDLES BANDED TOGETHER FOR HANDLING EASE. TO AVOID DAMAGE, TRUSSES SHOULD BE LEFT IN THESE BUNDLES UNTIL READY FOR INSTALLATION IN STRUCTURE. A CARELESS CRANE OR FORKLIFT OPERATOR CAN DAMAGE G2T TRUSSES. NEVER HANDLE G2T TRUSSES FLAT - KEEP IN AN UPRIGHT POSITION.

STORAGE OF G2T OPEN WEB TRUSSES

DURING STORAGE AT THE JOBSITE, KEEP G2T TRUSSES IN AN UPRIGHT POSITION. THE BUNDLES SHOULD BE SUPPORTED ON LEVEL STICKERS TO KEEP THE G2T TRUSSES OUT OF THE MUD AND DIRT. STACKING OF BUNDLES IS PERMITTED IF AN ADEQUATE NUMBER OF STICKERS ARE PROVIDED TO PREVENT DAMAGE AND NORMAL SAFETY PRECAUTIONS ARE FOLLOWED. ALL GLUE USED IN G2T TRUSSES IS WATER PROOF. HOWEVER, LONG EXPOSURE TO WATER AND SUN WILL CAUSE SOME DEGRADATION AND CHECKING OF WOOD. G2T TRUSSES SHOULD RECEIVE THE SAME PROTECTION FROM WEATHER AS OTHER WOOD PRODUCTS.

TYPICAL G2T PROJECT NOTES:

- FOR NOTES, DETAILS, AND DIMENSIONS NOT ON THESE SHOP DRAWINGS, REFER TO PROJECT PLANS.
- SEE BILLS OF MATERIAL FOR ITEMS FURNISHED.
- ALL CLOUDED NOTES, DIMENSIONS, ETC. REQUIRE VERIFICATION AND MUST BE MARKED EITHER "OK" OR THE CORRECT INFORMATION PROVIDED BY CUSTOMER, PRIOR TO RETURN TO BEING RETURNED FOR FABRICATION.
- PLEASE BE AWARE THAT ANY CLOUDED ITEMS NOT ACKNOWLEDGED WILL REQUIRE CONTACT WITH RESPONSIBLE PARTIES AND MAY CAUSE DELAY IN THE PROCESSING OF YOUR ORDER.
- PLEASE VERIFY THAT ALL INFORMATION PROVIDED HEREWITH REFLECTS THE LATEST AVAILABLE PROJECT INFORMATION AND THAT ALL G2T TRUSS LENGTHS CORRESPOND WITH ACTUAL FIELD DIMENSIONS PRIOR TO BEING RETURNED FOR FABRICATION.
- ALL BRACING SHOWN IS INTEGRAL TO THE G2T OPEN WEB TRUSS SYSTEM AND TEMPORARY BRACING. THE G2T OPEN WEB TRUSS WILL NOT SAFELY SUPPORT LOADS UNTIL FULLY BRACED, FULLY ATTACHED TO BEARING WALLS OR BEAMS, AND SHEATHING, BY OTHERS IS PROPERLY INSTALLED (SEE LAYOUTS AND DETAILS).
- POINT LOADS THAT EXCEED 100 LBS. AS INDICATED ON THE LAYOUT HEREIN.
- INSTALLATION OF G2T OPEN WEB TRUSSES MUST FOLLOW ANY ADDITIONAL REQUIREMENTS INDICATED ON THE LAYOUTS AND IN THE CALCULATIONS.
- ALL G2T OPEN WEB TRUSSES ARE DESIGNED FOR UNIFORM LOADS AND CONCENTRATED LOADS NOTED ON THESE DRAWINGS AND CALCULATIONS. TEMPORARY CONSTRUCTION LOADS WHICH CAUSE STRESSES BEYOND DESIGN CRITERIA ARE NOT PERMITTED.
- ALL 2X, 4X, 6X ETC. FRAMING TO BE SUPPLIED BY OTHERS, UNO. (FMBO).
- METAL STRAPS AND/OR TIES USED FOR SEISMIC PURPOSES THAT ARE NAILED TO THE TOP OF THE TOP CHORD ARE TO USE 10d NAILING AT NO LESS THAN 3" @ IN A ROW. ACCEPTABLE STRAPS FOR G2T TOP CHORDS ARE LTI, LSTI, MSTI AND PAL.
- G2T OPEN WEB TRUSS ARE NOT DESIGNED TO SUPPORT ANY FIRE SPRINKLER AND/OR MECHANICAL LOADS OTHER THAN WHAT IS SHOWN ON THESE SHOP DRAWINGS, AND OR WHAT HAS BEEN PROVIDED IN THE DESIGN DEAD LOAD(S).
- THE PLACEMENT OF THE MECHANICAL UNITS AND SPRINKLER MAINS ARE TO BE AS NOTED ON THESE SHOP DRAWINGS. THE SUPPORTING TRUSSES HAVE BEEN SPECIFICALLY DESIGNED TO ACCOMMODATE THESE ITEMS. ALL COMPONENTS TRANSFERRING LOADS TO THE TRUSSES SHALL BE DESIGNED AND INSTALLED IN ACCORDANCE WITH THE DETAILS CONTAINED WITHIN THESE DRAWINGS.
- G2T TRUSS DESIGNS ARE IN ACCORDANCE WITH THE CURRENT ADOPTED EDITION OF THE IBC, CBC, AND NATIONAL DESIGN SPECIFICATION, AND CONFORM TO CURRENT ICC-ES REPORT.

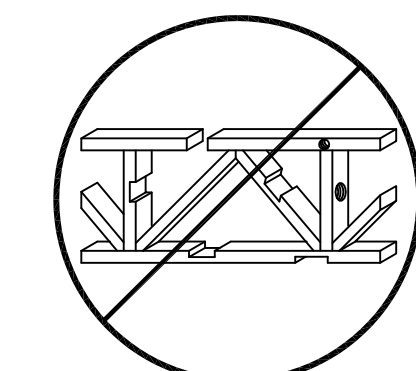

DO NOT CUT, DRILL OR NOTCH CHORDS AND WEB MEMBERS

9 G2T TRUSS NOTES

WARNING:
Drilling, sawing, sanding or machining wood products generates wood dust and other substances known to cause cancer. Avoid inhaling dust generated from wood products or use a dust mask or other safeguards for personal protection.
Wood products emit chemicals known to cause birth defects or other reproductive harm.

LEGEND / ABBREVIATIONS

- SEE PROJECT PLANS FOR OTHER ABBREVIATIONS AND SYMBOLS USED.
- DETAIL (ON SHOP DRAWINGS)
 - PROJECT PLAN DETAIL (PER PLANS)
 - START G2T TRUSS LAYOUT @ o/c SPACING
 - ↔ STRONGBACK LOCATION
 - ↘ DIRECTION OF ROOF SLOPE
- FMBO = FRAMING MATERIAL BY OTHERS
VF = VERIFY IN FIELD
NIC = NOT IN CONTRACT
UNO = UNLESS NOTED OTHERWISE
FSML = FIRE SPRINKLER MAIN LINE
FIT = FACE TO FACE (CLEAR SPAN OF TRUSS)
MTL = MANUFACTURED TRUSS LENGTH
OTCL = OVERALL TOP CHORD LENGTH (SLOPE LENGTH)
LBS = POUNDS
PSF = POUNDS PER SQUARE FOOT
PLF = POUNDS PER LINEAL FOOT
MFR. = MANUFACTURER
> = GREATER THAN (< = LESS THAN)
@/c O.C. = ON CENTER (SPACING)
B/O.G. = BILL(S) OF MATERIAL (8 1/2 x 11 SHEETS)
DBL = DOUBLE MEMBER (TPL = TRIPLE MEMBER)

REVISIONS	DATE	DESCRIPTION
1		
2		
3		
4		
5		

BELLA VIA VILLAGE SHOPS(G)
4425 S. MOUNTAIN RD.
MESA, AZ 85212

ENGINEER
SIMPSON STRONGTIE
602-443-0303
FUNCTIONAL FORMATION ARCHITECTURE, LLC
480-726-6555
CUSTOMER
BAILEY MARSHALL GROUP
480-475-8854

G2 STRUCTURAL
G2 STRUCTURAL, LLC
4400 N. SCOTTSDALE RD. #9396, SCOTTSDALE, AZ 85251

12/14/2017
PN-12431
SHEET
1 OF 3

PROJECT PLANS USED:	
SHEETS	DATE
ARCHITECTURAL DRAWINGS	
T1 THRU A11	11/15/16
STRUCTURAL DRAWINGS	
S1 THRU S8	11/15/16
MECHANICAL DRAWINGS	
M1 THRU P2	11/15/16

DESIGN LOADS	
LIVE LOAD	20 PSF
PART LOAD	- PSF
DEAD LOAD	18 PSF
TOTAL LOAD	38 PSF

DESIGN DEFLECTION:
 $\Delta_{LL} \leq L/240$ $\Delta_{TL} \leq L/180$
 LOAD DURATION FACTOR = 1.25
 DESIGN CODE: IRC 2008
 DEAD LOAD BRISQACROW: 14 PSF TC
 30 MPH WIND EXP. C 4 PSF BC
 NET WIND UPLIFT: 9 PSF
 2.8K AXIAL LOAD
 - ROOF LIVE LOAD REDUCIBLE PER CODE
 - ADDITIONAL 500# MISC POINT LOAD OCCURRING AT ANY ONE TOP CHORD PANEL POINT ALONG THE SPAN CONCURRENT WITH UNIFORM DEAD LOAD AND LIVE LOAD ONLY.

NOTE: SPRINKLER LINES GREATER THAN 3" DIAMETER HAVE NOT BEEN CONSIDERED IN THE TRUSS DESIGNS

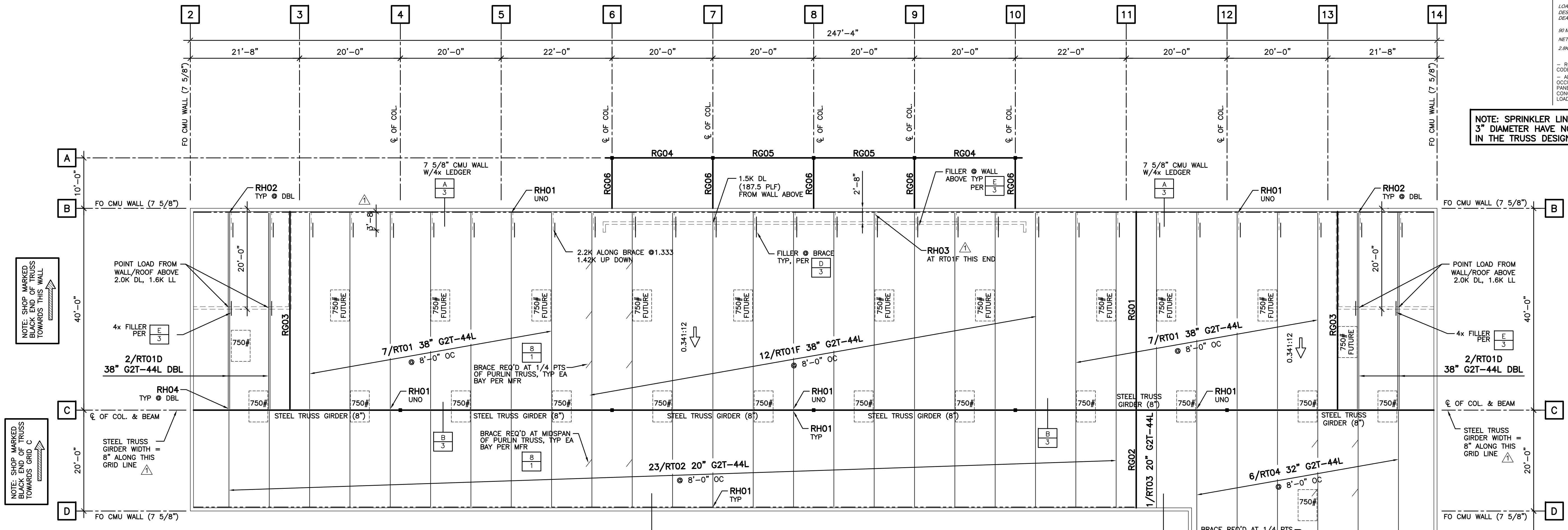

24F-V4/V8 DF OR 26F-V5 SP
 FINAL LAMINATING COMBINATION TO BE BASED ON MANUFACTURER LEAD TIMES INDUSTRIAL APPEARANCE GRADE UNO

QTY	MARK	WIDTH	DEPTH	LENGTH	CAMBER
1	RG01	5 1/8"	24"	39'-6"	1 1/4"
1	RG02	5 1/8"	15"	19'-6"	STD
2	RG03	5 1/8"	28 1/2"	40'-0"	1 1/2"
2	RG04	5 1/8"	12"	21'-6"	STD
2	RG05	5 1/8"	12"	20'-6"	STD
5	RG06	5 1/8"	12"	10'-0"	STD

G2T TRUSS LIST						
MARK	QTY	CLR SPAN	MFR LENGTH	DEPTH	HANGER (BLACK END)	HANGER (OTHER END)
RT01D	4	38'-8 7/8"	38'-8 1/8"	38" G2T-44L DBL	BH414X-2	BH414X-2
RT01F	12	38'-8 7/8"	38'-8 1/8"	38" G2T-44L	BHV414X	BHV414X
RT01	14	38'-8 7/8"	38'-8 1/8"	38" G2T-44L	BHV414X	BHV414X
RT02	23	18'-8 7/8"	18'-8 1/8"	20" G2T-44L	BHV414X	BHV414X
RT03	1	19'-0 3/8"	18'-11 5/8"	20" G2T-44L	BHV414X	BHV414X
RT04	6	32'-0 7/8"	32'-0 1/8"	32" G2T-44L	BHV414X	BHV414X
RT05	4	40'-4 7/8"	40'-4 1/8"	38" G2T-44L	BHV414X	BHV414X
RT06	4	17'-0 7/8"	17'-0 1/8"	20" G2T-44L	BHV414X	BHV414X

MISC. MATERIAL LIST		
ITEM	QTY	USE
PB40	148	STD G2T B/C BRACING (SEE DETAIL 8/1)

KC METALS CONNECTORS ESR-2930					
QTY	MARK	DESCRIPTION	NAILING		REMARKS
			HEADER	JOIST	
116	RH01	BHV414X H=14", W=3 5/8"	10-16d	6-16dx2 1/2"	WELDED @ STEEL TRUSS GIRDER
8	RH02	BH414X-2 H=14", W=7 1/4" B=3"	10-N25	PRE-DRILL	WELDED @ STEEL TRUSS GIRDER
12	RH03	BH414X H=14", W=3 5/8" B=3"	10-N25	PRE-DRILL	WELDED @ STEEL TRUSS GIRDER

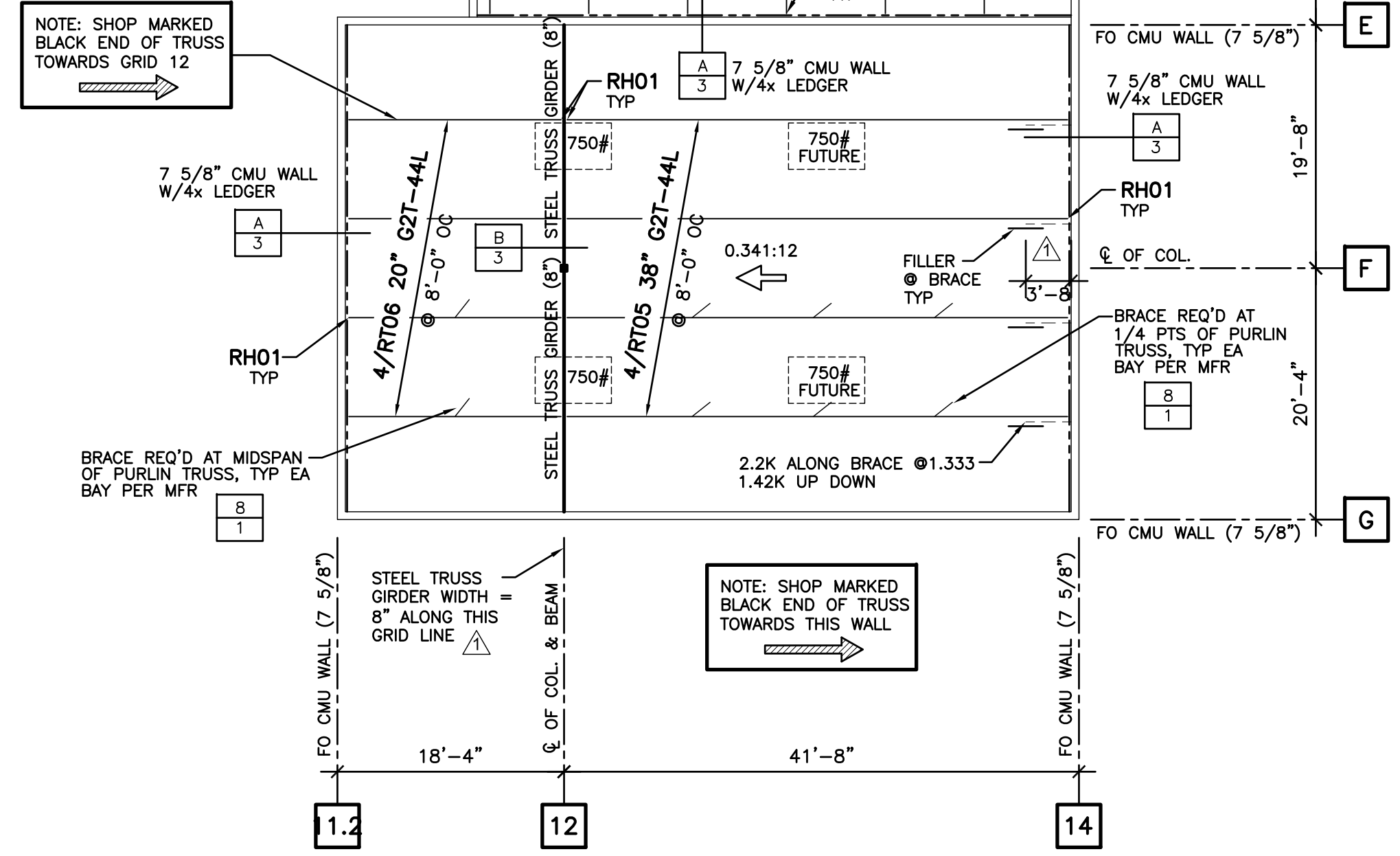

ROOF PRODUCT PLACEMENT PLAN

(REF: S4)
 SCALE: 3/32" = 1'-0"

REVISIONS	
1	1-26-18 Per review comments and steel girder width provided
2	
3	
4	

BELLA VIA VILLAGE SHOPS(G)
 4425 S. MOUNTAIN RD.
 MESA, AZ 85212

ENGINEER
 SIMPLY STRONG ARCHITECTURAL, INC.
 602-443-0303
 4850 W. WASHINGTON
 FUNCTIONAL FORMATION ARCHITECTURE, LLC
 480-726-4555
 CUSTOMER
 BAILEY MARSHALL GROUP
 480-475-8854

G2 STRUCTURAL
 G2 STRUCTURAL, LLC
 4400 N. SCOTTSDALE RD. #6396, SCOTTSDALE, AZ 85251

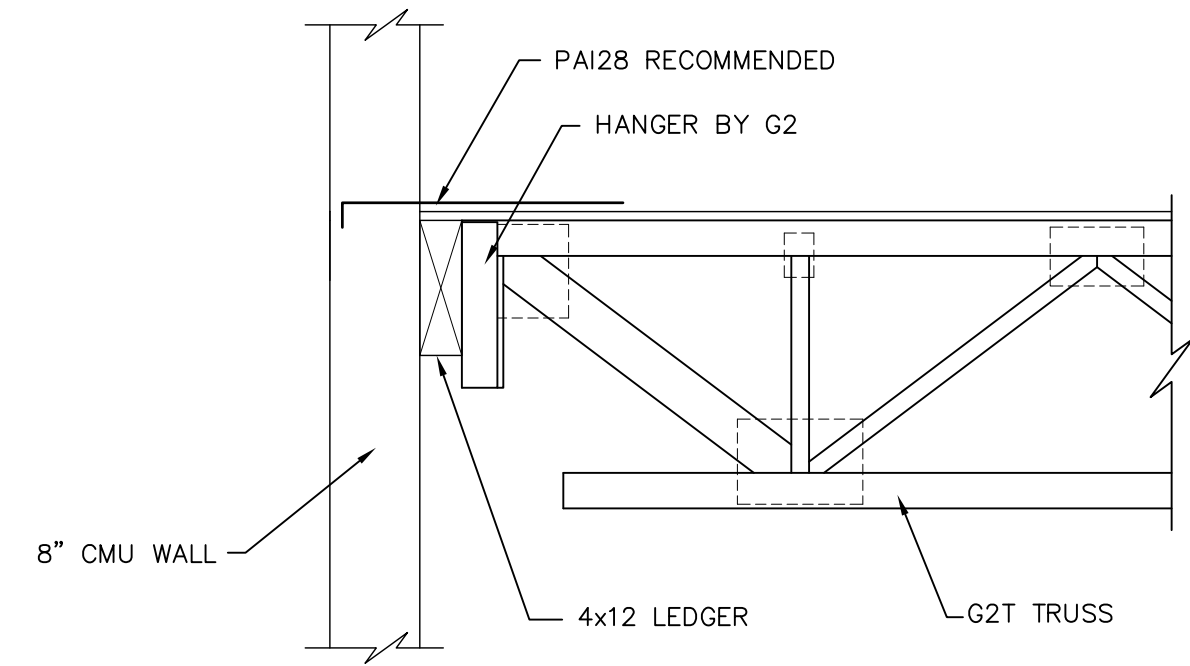

REF: 204/S6

A
-

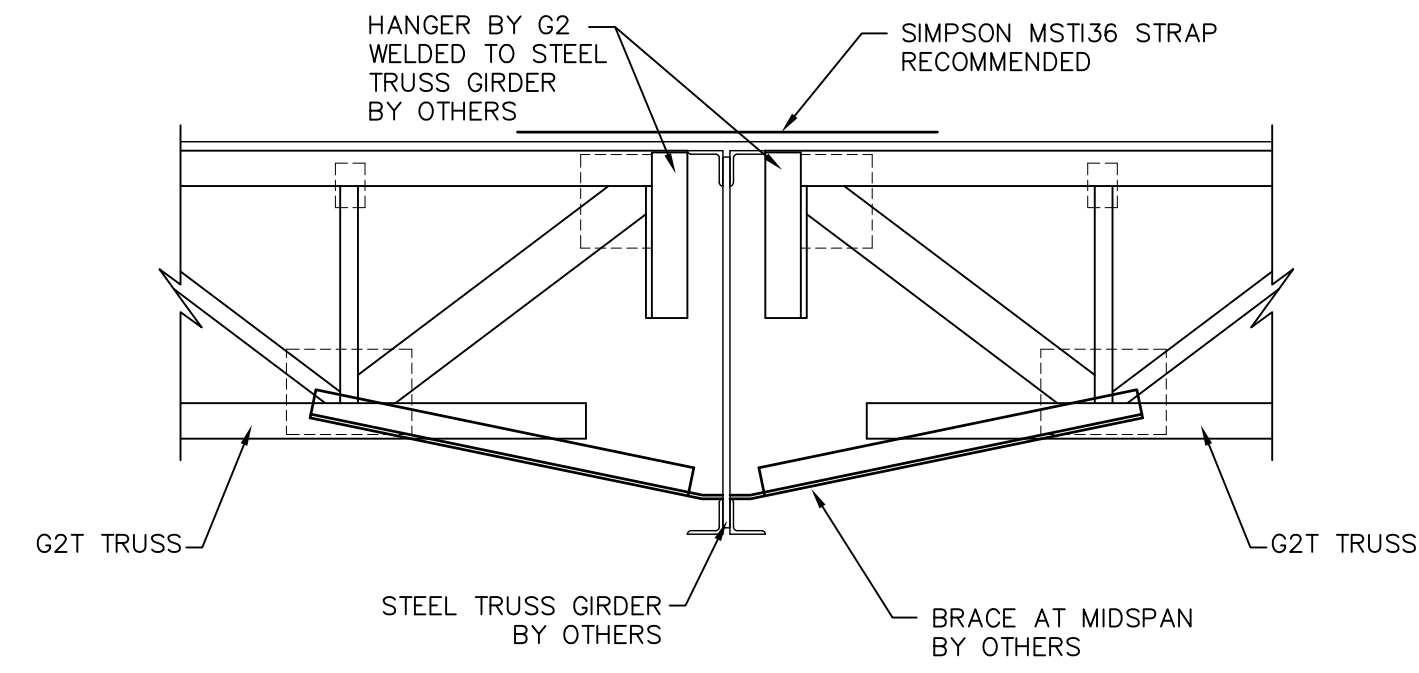

REF: 203/S6

B
-

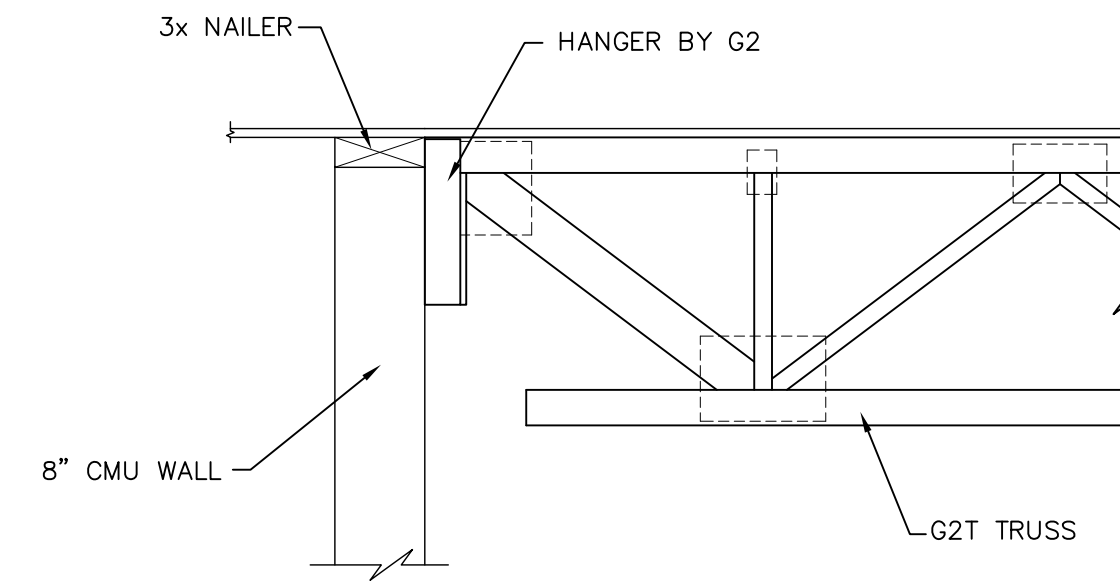

REF: 217/S6

C
-

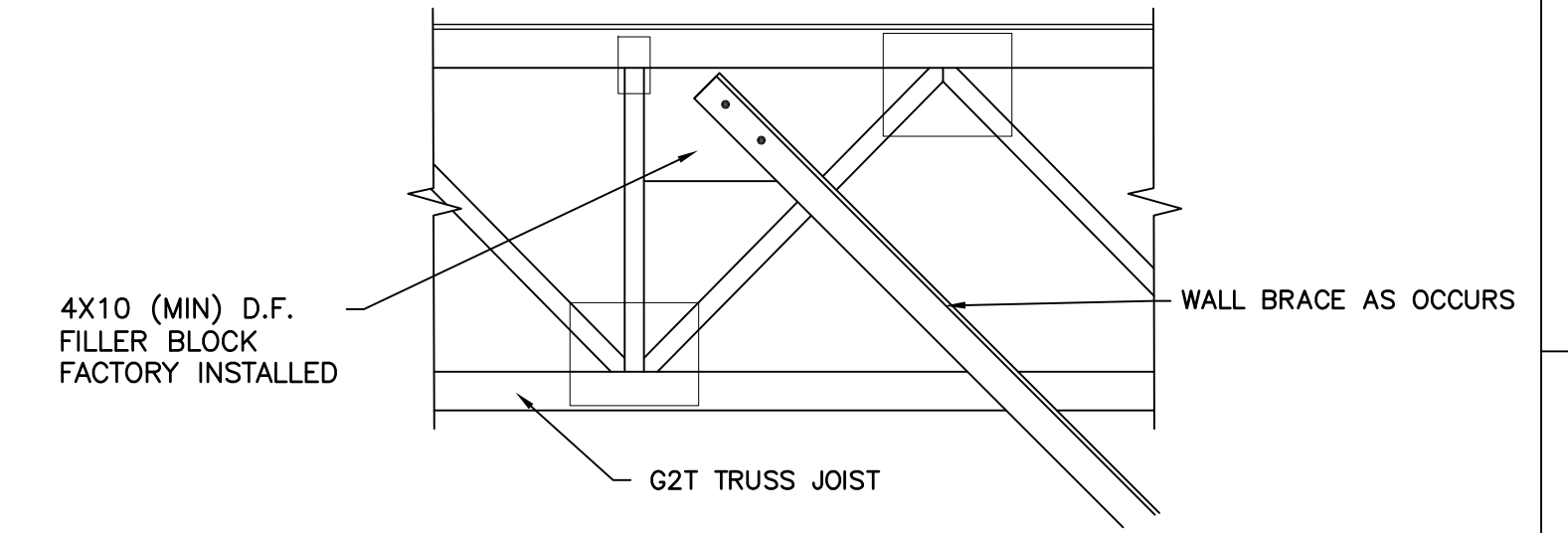

D
-

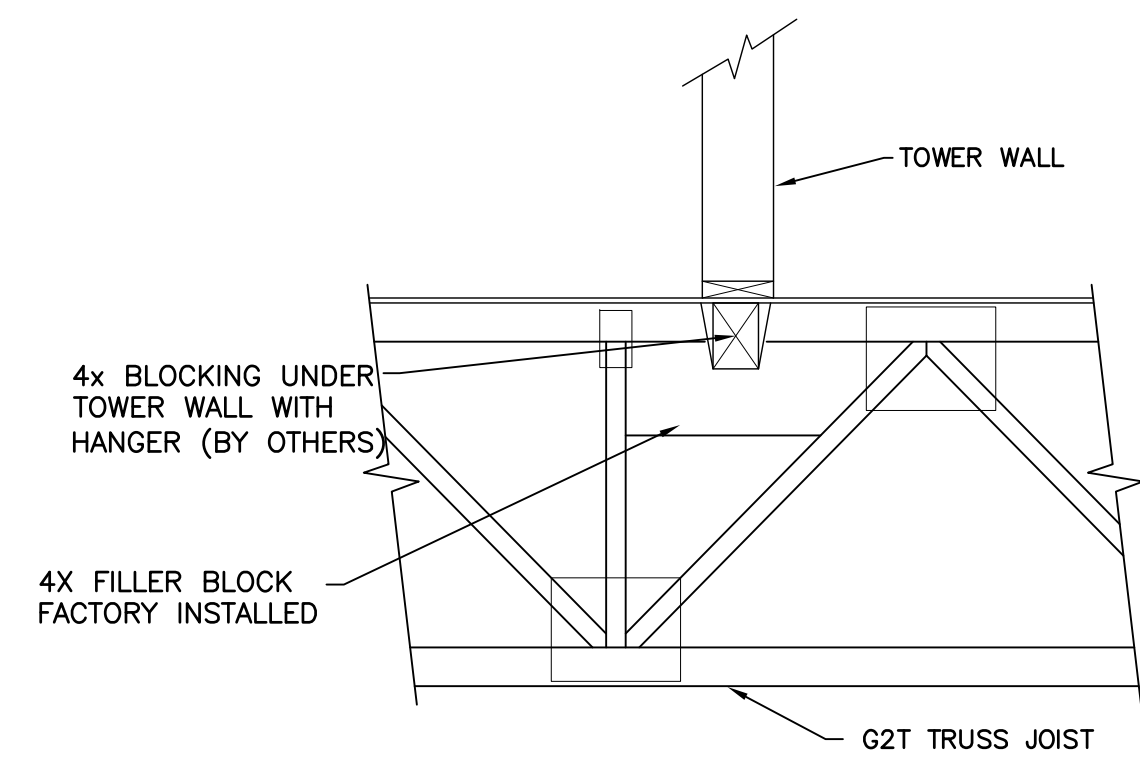

E
-

REVISIONS	
1	1-26-18
2	
3	
4	
5	

BELLA VIA VILLAGE SHOPS(G)
 4425 S. MOUNTAIN RD.
 MESA, AZ 85212

ENGINEER
 SIMPLY STRUCTURAL, INC.
 602-442-9393
 ARCHITECT
 FUNCTIONAL FORMATION ARCHITECTURE, LLC
 480-728-6595
 CUSTOMER
 BAILEY MARSHALL GROUP
 480-475-8854

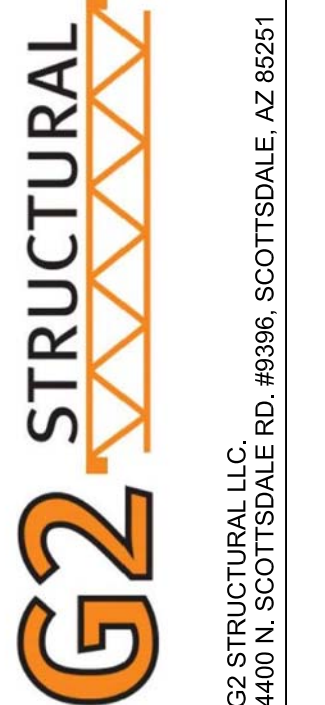

PN-12431
 SHEET
 3 OF 3

REVISED FOR CONSTRUCTION